

UNCONTROLLED DOCUMENT

PART NUMBER
SSP-LXC04362S3A

REV.

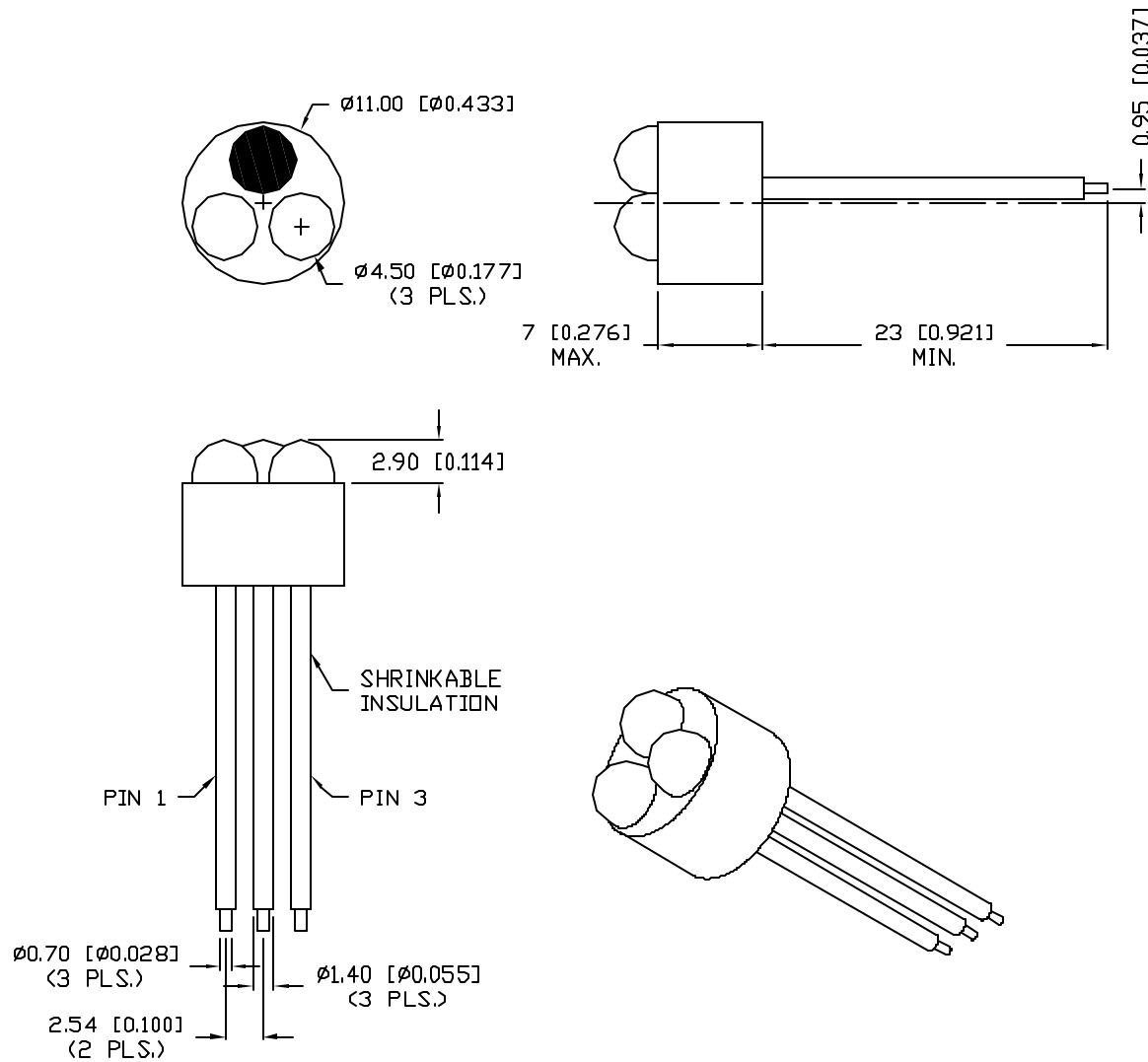

ELECTRO-OPTICAL CHARACTERISTICS $T_A=25^\circ\text{C}$ $I_f=20/40\text{mA}$

PARAMETER	MIN	TYP	MAX	UNITS	TEST COND
PEAK WAVELENGTH		660 (R)		nm	
		565 (G)		nm	
FORWARD VOLTAGE* (R/G)		1.8/2.2	2.3/2.6	V_f	
REVERSE VOLTAGE (R/G)	4.0/5.0			V_r	$I_f=100\mu\text{A}$
AXIAL INTENSITY** (R/G)		2000/300		mcd	$I_f=20/40\text{mA}$
VIEWING ANGLE		30		2x theta	
EMITTED COLOR:	SUPER RED/SUPER GREEN				
EPOXY LENS FINISH:	WATER CLEAR				

* VOLTAGE FOR PIN 1/VOLTAGE FOR PIN 3
** INTENSITY PER DIE. TEST CONDITION: CURRENT FOR PIN 1/PIN 3

LIMITS OF SAFE OPERATION AT 25°C PER DIE

PARAMETER	COLORS	MAX	UNITS
PEAK FORWARD CURRENT*		150	mA
STEADY CURRENT	(R/G)	30/25	mA
POWER DISSIPATION		105	mW
DERATE FROM 25°C		-1.2	mW/ $^\circ\text{C}$
OPERATING, STORAGE TEMP.		-30 TO +70	$^\circ\text{C}$
SOLDERING TEMP.		+260	$^\circ\text{C}$
2.0mm FROM BODY			3 SEC. MAX

* $t < 10\mu\text{s}$

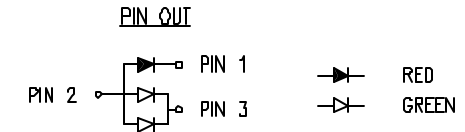

UNCONTROLLED DOCUMENT

*TOLERANCES PER DECIMAL PRECISION ARE: X= ± 1 (± 0.039), X,X= ± 0.5 (± 0.020), X,X,X= ± 0.25 (± 0.010). LEAD LENGTH= ± 0.75 (± 0.030), MIN. $\frac{+0.00}{-0.00}$ MAX. $\frac{+0.00}{-0.00}$

REV.

PART NUMBER

SSP-LXC04362S3A

CONFIDENTIAL INFORMATION

THE INFORMATION CONTAINED IN THIS DOCUMENT IS THE PROPERTY OF SUNBRITE LEDS. EXCEPT AS SPECIFICALLY AUTHORIZED IN WRITING BY SUNBRITE LEDS, THE HOLDER OF THIS DOCUMENT SHALL KEEP ALL INFORMATION CONTAINED HEREIN CONFIDENTIAL AND SHALL PROTECT SAME IN WHOLE OR IN PART FROM DISCLOSURE AND DISSEMINATION TO ALL THIRD PARTIES.

RELIABILITY NOTE

OUR MANY YEARS OF EXPERIENCE DATA ACCUMULATION INDICATE THAT SOLDER HEAT IS A MAJOR CAUSE OF EARLY AND FUTURE FAILURE. PLEASE PAY ATTENTION TO YOUR SOLDERING PROCESS.



286 E. HELEN ROAD
PALATINE, IL 60067-6976
PHONE: +1.847.359.2790
FAX: +1.847.359.2867
WEB: www.sunbriteleds.com

0.43" CIRCULAR, 3 LED CLUSTER, COMMON ANODE,
660nm RED/565nm GREEN LEDS, WATER CLEAR LENS.

DRAWN: BC CHECKED: APPROVED: DATE: 1.17.00
PAGE: 1 OF 1